



VERTICAL ELEVATOR

MAIN ADVANTAGE

Full washdown duty with Minimum footprint Design

FEATURES AND USES

The Storcan Vertical Elevator is a continuous vertical conveyor specifically suitable for average to high-capacity applications.

This equipment can be used to transport a wide variety of products, effortlessly and quickly, like boxes, cases or trays to and from any height you require. It can be used for both ascending and descending product flow.

The product is always carried in an upright position without the risk of product deformation.

It comes with its own control panel for better local synchronization and use only standard induction sensors to simplify its use.



TECHNICAL SPECIFICATIONS

Frame	304 # 4 11ga stainless steel bolted structure
Motor	Keltech stainless steel IP69K Or Sew Eurodrive epoxy (voltage to be determined)
Rate	16-20 cases / minute - depending on height & configuration of elevator
Maximum load	50 kg / case
Maximum case	33 lg x 24 h x 24 l (can be customized)
Security	Include 36" Security guarding on the entrance Electric Motor brake
Included basic components	Include Food Grade White Bearings Stainless Steel Sprocket Include a lube system for chain
Options	Light curtain and Photocell Transmission with Zinc plated Chain

LAYOUT

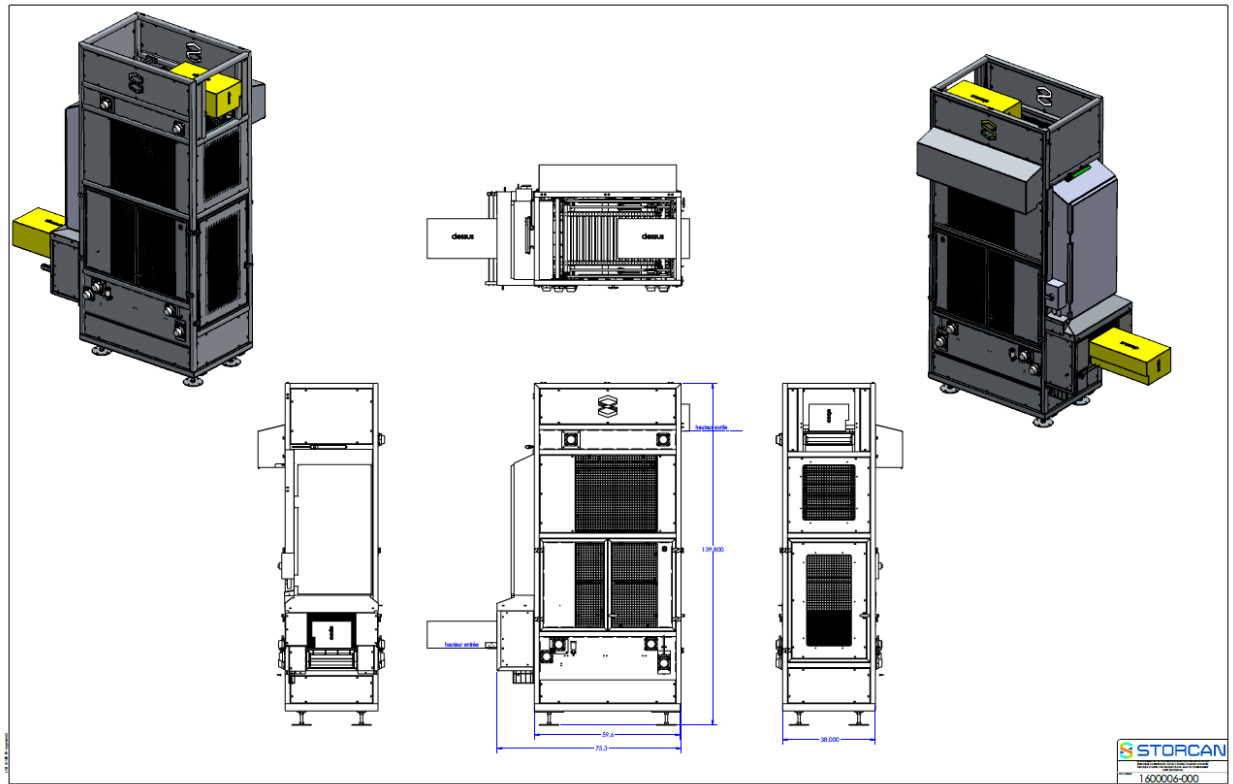

MODELS AND APPLICATIONS

